

Why Did the World Trade Center Collapse?—Simple Analysis¹

Zdeněk P. Bažant, F.ASCE,² and Yong Zhou³

Abstract: This paper presents a simplified approximate analysis of the overall collapse of the towers of World Trade Center in New York on September 11, 2001. The analysis shows that if prolonged heating caused the majority of columns of a single floor to lose their load carrying capacity, the whole tower was doomed.

DOI: 10.1061/(ASCE)0733-9399(2002)128:1(2)

CE Database keywords: New York; New York City; Disasters; Buildings; High-rise; Collapse; Analysis; Terrorism.

Introduction and Failure Scenario

The 110-story towers of the World Trade Center were designed to withstand as a whole the forces caused by a horizontal impact of a large commercial aircraft (Appendix I). So why did a total collapse occur? The cause was the dynamic consequence of the prolonged heating of the steel columns to very high temperature. The heating lowered the yield strength and caused viscoplastic (creep) buckling of the columns of the framed tube along the perimeter of the tower and of the columns in the building core. The likely scenario of failure is approximately as follows.

In stage 1 (Fig. 1), the conflagration, caused by the aircraft fuel spilled into the structure, causes the steel of the columns to be exposed to sustained temperatures apparently exceeding 800°C. The heating is probably accelerated by a loss of the protective thermal insulation of steel during the initial blast. At such temperatures, structural steel suffers a decrease of yield strength and exhibits significant viscoplastic deformation (i.e., creep—an increase of deformation under sustained load). This leads to creep buckling of columns (Bažant and Cedolin 1991, Sec. 9), which consequently lose their load carrying capacity (stage 2). Once more than half of the columns in the critical floor that is heated most suffer buckling (stage 3), the weight of the upper part of the

structure above this floor can no longer be supported, and so the upper part starts falling down onto the lower part below the critical floor, gathering speed until it impacts the lower part. At that moment, the upper part has acquired an enormous kinetic energy and a significant downward velocity. The vertical impact of the mass of the upper part onto the lower part (stage 4) applies enormous vertical dynamic load on the underlying structure, far exceeding its load capacity, even though it is not heated. This causes failure of an underlying multifloor segment of the tower (stage 4), in which the failure of the connections of the floor-carrying trusses to the columns is either accompanied or quickly followed by buckling of the core columns and overall buckling of the framed tube, with the buckles probably spanning the height of many floors (stage 5, at right), and the upper part possibly getting wedged inside an emptied lower part of the framed tube (stage 5, at left). The buckling is initially plastic but quickly leads to fracture in the plastic hinges. The part of building lying beneath is then impacted again by an even larger mass falling with a greater velocity, and the series of impacts and failures then proceeds all the way down (stage 5).

Elastic Dynamic Analysis

The details of the failure process after the decisive initial trigger that sets the upper part in motion are of course very complicated and their clarification would require large computer simulations. For example, the upper part of one tower is tilting as it begins to fall (Appendix II); the distribution of impact forces among the underlying columns of the framed tube and the core, and between the columns and the floor-supporting trusses, is highly nonuniform; etc. However, a computer is not necessary to conclude that the collapse of the majority of columns of one floor must have caused the whole tower to collapse. This may be demonstrated by the following elementary calculations, in which simplifying assumptions most optimistic in regard to survival are made.

For a short time after the vertical impact of the upper part, but after the elastic wave generated by the vertical impact has propagated to the ground, the lower part of the structure can be approximately considered to act as an elastic spring [Fig. 2(a)]. What is its stiffness C ? It can vary greatly with the distribution of the impact forces among the framed tube columns, between these columns and those in the core, and between the columns and the trusses supporting concrete floor slabs.

¹The original version with Eqs. (1) and (2) was originally submitted to ASCE on September 13, 2001, and an expanded version with Eq. (3) was submitted to ASCE on September 22, 2001. The appendices were added between September 28 and October 5, 2001; The preliminary report (Bažant and Zhou 2001) on which this article is based was posted on September 14, 2001, at (<http://www.civil.northwestern.edu/news>), (<http://www3.tam.uiuc.edu/news/200109wtc>), and (<http://math.mit.edu/~bazant>).

²Walter P. Murphy Professor of Civil Engineering and Materials Science, Northwestern Univ., Evanston, IL 60208. E-mail: z-bazant@northwestern.edu

³Graduate Research Assistant, Northwestern Univ., Evanston, IL 60208.

Note. Associate Editor: Stein Sture. Discussion open until June 1, 2002. Separate discussions must be submitted for individual papers. To extend the closing date by one month, a written request must be filed with the ASCE Managing Editor. The manuscript for this rapid communication was submitted for review and possible publication on September 19, 2001; approved on October 8, 2001. This paper is part of the *Journal of Engineering Mechanics*, Vol. 128, No. 1, January 1, 2002. ©ASCE, ISSN 0733-9399/2002/1-2-6/\$8.00+\$5.00 per page.

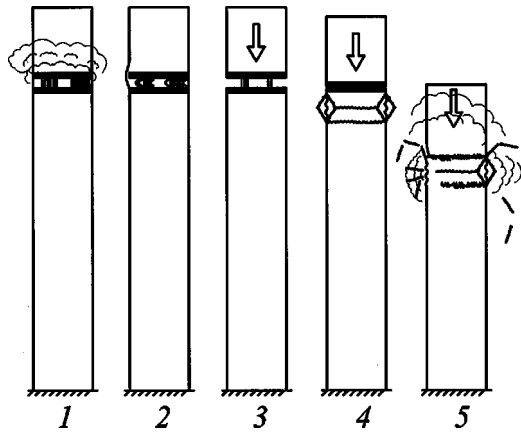

Fig. 1. Stages of collapse of the building (floor height exaggerated)

For our purpose, we may assume that all the impact forces go into the columns and are distributed among them equally. Unlikely though such a distribution may be, it is nevertheless the most optimistic hypothesis to make because the resistance of the building to the impact is, for such a distribution, the highest. If the building is found to fail under a uniform distribution of the impact forces, it would fail under any other distribution. According to this hypothesis, one may estimate that $C \approx 71$ GN/m (due to unavailability of precise data, an approximate design of column cross sections had to be carried out for this purpose).

The downward displacement from the initial equilibrium position to the point of maximum deflection of the lower part (considered to behave elastically) is $h + (P/C)$ where $P =$ maximum force applied by the upper part on the lower part and $h =$ height of critical floor columns ($=$ height of the initial fall of the upper part) ≈ 3.7 m. The energy dissipation, particularly that due to the inelastic deformation of columns during the initial drop of the upper part, may be neglected, i.e., the upper part may be assumed to move through distance h almost in a free fall (indeed, the energy dissipated in the columns during the fall is at most equal to $2\pi \times$ the yield moment of columns, \times the number of columns, which is found to be only about 12% of the gravitational potential energy release if the columns were cold, and much less than that at 800°C). So the loss of the gravitational potential energy of the upper part may be approximately equated to the strain energy of the lower part at maximum elastic deflection. This gives the equation $mg[h + (P/C)] = P^2/2C$ in which $m =$ mass of the upper part (of North Tower) $\approx 58 \times 10^6$ kg, and $g =$ gravity acceleration. The

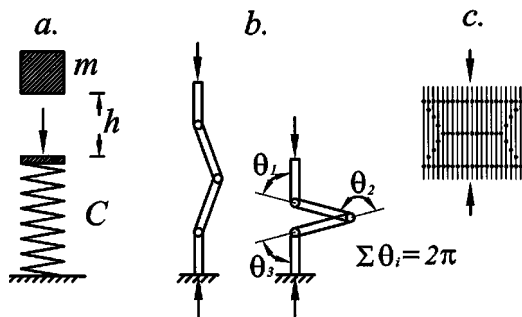

Fig. 2. (a) Model for impact of upper part on lower part of building; (b) Plastic buckling mechanism on one column line; (c) Combination of plastic hinges creating a buckle in the tube wall

solution $P = P_{\text{dyn}}$ yields the following elastically calculated overload ratio due to impact of the upper part:

$$P_{\text{dyn}}/P_0 = 1 + \sqrt{1 + (2Ch/mg)} \approx 31 \quad (1)$$

where $P_0 = mg =$ design load capacity. In spite of the approximate nature of this analysis, it is obvious that the elastically calculated forces in columns caused by the vertical impact of the upper part must have exceeded the load capacity of the lower part by at least an order of magnitude.

Another estimate, which gives the initial overload ratio that exists only for a small fraction of a second at the moment of impact, is

$$P_{\text{dyn}}/P_0 = (A/P_0) \sqrt{2\rho g E_{ef} h} \approx 64.5 \quad (2)$$

where $A =$ cross section area of building; $E_{ef} =$ cross section stiffness of all columns divided by A ; and $\rho =$ specific mass of building per unit volume. This estimate is calculated from the elastic wave equation which yields the intensity of the step front of the downward pressure wave caused by the impact if the velocity of the upper part at the moment of impact on the critical floor is considered as the boundary condition (Bažant and Cedolin 1991, Sec. 13.1). After the wave propagates to the ground, the former estimate is appropriate.

Analysis of Inelastic Energy Dissipation

The inelastic deformation of the steel of the towers involves plasticity and fracture. Since we are not attempting to model the details of the real failure mechanism but seek only to prove that the towers must have collapsed and do so in the way seen (“Massive” 2001; *American* 2001), we will here neglect fracture, even though the development of fractures, especially in column connections, is clearly discerned in the photographs of the collapse. Assuming the steel is to behave plastically, with unlimited ductility, we are making the most optimistic assumption with regard to the survival capacity of the towers (in reality, the plastic hinges, especially the hinges at column connections, must have fractured, and done so at relatively small rotation, causing the load capacity to drop drastically).

The basic question to answer is: Can the fall of the upper part be arrested by energy dissipation during plastic buckling, which follows the initial elastic deformation? Many plastic failure mechanisms could be considered, for example: (1) the columns of the underlying floor buckle locally (Fig. 1, stage 2); (2) the floor-supporting trusses are sheared off at the connections to the framed tube and to the core columns and fall down within the tube, depriving the core columns and the framed tube of lateral support, and thus promoting buckling of the core columns and of the framed tube under vertical compression [Fig. 1, stage 4, and Fig. 2(c)]; or (3) the upper part is partly wedged within the emptied framed tube of the lower part, pushing the walls of the framed tube apart (Fig. 1, stage 5). Although each of these mechanisms can be shown to lead to total collapse, a combination of the last two seems more realistic [the reason: multistory pieces of the framed tube, with nearly straight boundaries apparently corresponding to plastic hinge lines causing buckles on the framed tube wall, were photographed falling down, “Massive 2001”; *American* 2001].

Regardless of the precise failure mode, experience with buckling indicates that while many elastic buckles simultaneously coexist in an axially compressed tube, the plastic deformation localizes (because of plastic bifurcation) into a single buckle at a time

[Fig. 1, stage 4, and Fig. 2(c)], and so the buckles must fold one after another. Thus, at least one plastic hinge, and no more than four plastic hinges, per column line are needed to operate simultaneously in order to allow the upper part to continue moving down [Fig. 2(b)] (Bažant and Cedolin 1991). (This is also true if the columns of only one floor are buckling at a time.) At the end, the sum of the rotation angles θ_i ($i = 1, 2, \dots$) of the hinges on one column line, $\Sigma\theta_i$, cannot exceed 2π [Fig. 2(b)]. This upper-bound value, which is independent of the number of floors spanned by the buckle, is used in the present calculations since, in regard to survival, it represents the most optimistic hypothesis, maximizing the plastic energy dissipation.

Calculating the dissipation per column line of the framed tube as the plastic bending moment M_p of one column (Jirásek and Bažant 2002) times the combined rotation angle $\Sigma\theta_i = 2\pi$ [Fig. 2(b)] and multiplying this by the number of columns, one concludes that the plastically dissipated energy W_p is, optimistically, of the order of 0.5 GN m (for lack of information, certain details such as the wall thickness of steel columns, were estimated by carrying out approximate design calculations for this building).

To attain the combined rotation angle $\Sigma\theta_i = 2\pi$ of the plastic hinges on each column line, the upper part of the building must move down by the additional distance of at least one floor below the floor where the collapse started, and so the total release of gravitational potential energy is $W_g = mg \cdot 2h \approx 2 \times 2.1 \text{ GN m} = 4.2 \text{ GN m}$. To arrest the fall, the kinetic energy of the upper part, which is equal to the potential energy release, would have to be absorbed by the plastic hinge rotations, i.e., W_p would have to be larger than W_g . Rather,

$$W_g / W_p \approx 8.4 \quad (3)$$

So, even under the most optimistic assumptions by far, the plastic deformation can dissipate only a small part of the kinetic energy acquired by the upper part of building.

When the next buckle with its group of plastic hinges forms, the upper part has already traveled many floors down and has acquired a much higher kinetic energy; the percentage of the kinetic energy dissipated plastically is then of the order of 1%. The percentage continues to decrease further as the upper part moves down. If fracturing in the plastic hinges were considered, a still smaller (in fact much smaller) energy dissipation would be obtained. So the collapse of the tower must be an almost free fall. This conclusion is supported by the observation that the duration of the collapse of each tower, reported as roughly 10 s, was about the same as the duration of a free fall in a vacuum from the tower top $H = 416 \text{ m}$ to the top of the heap of debris ($H_0 = 25 \text{ m}$), which is $t = \sqrt{2(H - H_0)/g} = 8.93 \text{ s}$. It further follows that the brunt of vertical impact must have gone directly into the columns of the framed tube and the core, and that the front of collapse of the floors could not have advanced substantially ahead of the front of collapse of the framed tube, since otherwise the collapse of the framed tube would have had to take significantly longer than 9 s.

Closing Comments and Problems of Disaster Mitigation

Designing tall buildings to withstand this sort of attack seems next to impossible. It would require a much thicker insulation of steel with blast-resistant protective cover. Replacing the rectangular framed tube by a hardened circular monolithic tube with tiny windows might help to deflect much of the debris of impacting

aircraft and the fuel sideways, but regardless of cost, who would want to work in such a building?

The problems appear to be equally severe for concrete columns because concrete heated to such temperatures undergoes explosive thermal spalling, thermal fracture, and disintegration due to dehydration (Bažant and Kaplan 1996). These questions arise not only for buildings supported on many columns but also for the recent designs of tall buildings with a massive monolithic concrete core functioning as a tubular mast. These recent designs use high-strength concrete which, however, is even more susceptible to explosive thermal spalling and thermal fracture than normal concrete. The use of refractory concretes as the structural material invites many open questions (Bažant and Kaplan 1996). Special alloys or various refractory ceramic composites may, of course, function at such temperatures, but the cost would increase astronomically.

It will nevertheless be appropriate to initiate research on materials and designs that would postpone the collapse of the building so as to extend the time available for evacuation, provide a hardened and better insulated stairwell, or even prevent collapse in the case of a less severe attack such as an off-center impact, or the impact of an aircraft containing less fuel.

An important puzzle at the moment is why the adjacent 46-story building, into which no significant amount of aircraft fuel could have been injected, collapsed as well. Despite the lack of data at present, the likely explanation seems to be that high temperatures (though possibly well below 800°C) persisted on at least one floor of that building for a much longer time than specified by the current fire code provisions.

Appendix I. Elastic Dynamic Response to Aircraft Impact

A simple estimate based on the preservation of the combined momentum of the impacting Boeing 767-200 ($\sim 179,000 \text{ kg} \times 550 \text{ km/h}$) and the momentum of the equivalent mass M_{eq} of the interacting upper half of the tower ($\sim 141 \times 10^6 \text{ kg} \times v_0$) indicates that the initial average velocity v_0 imparted to the upper part of the tower was only about $0.7 \text{ km/h} = 0.19 \text{ m/s}$. The response may be assumed to be dominated by the first free vibration mode, of period T_1 . Then the maximum deflection $w_0 = v_0 T_1 / 2\pi$. Approximately, $T_1 = 14 \text{ s}$, based on estimating (very roughly) the bending stiffness of the tower and approximating it as a vibrating cantilever of a uniform mass distribution. This gives $w_0 = 0.4 \text{ m}$, which is well within the range of the elastic behavior of the tower. So it is not surprising that the aircraft impact per se damaged the tower only locally.

The World Trade Center was designed for an impact of a Boeing 707-320 rather than a Boeing 767-200. But note that the maximum takeoff weight of that older aircraft is only 15% less than that of a Boeing 767-200. Besides, the maximum fuel tank capacity of that aircraft is only 4% less. These differences are well within the safety margins of design. So the observed response of the towers proves the correctness of the dynamic design. What was not considered in design was the temperature that can develop in the ensuing fire. Here the experience from 1945 might have been deceptive. That year, a two-engine bomber (B-25), flying at about 400 km/h , hit in fog the Empire State Building (381-m tall, built in 1930) at the 79th floor (278 m above ground)—the steel structure suffered no significant damage, and the fire was confined essentially to one floor (Levy and Salvadori 1992).

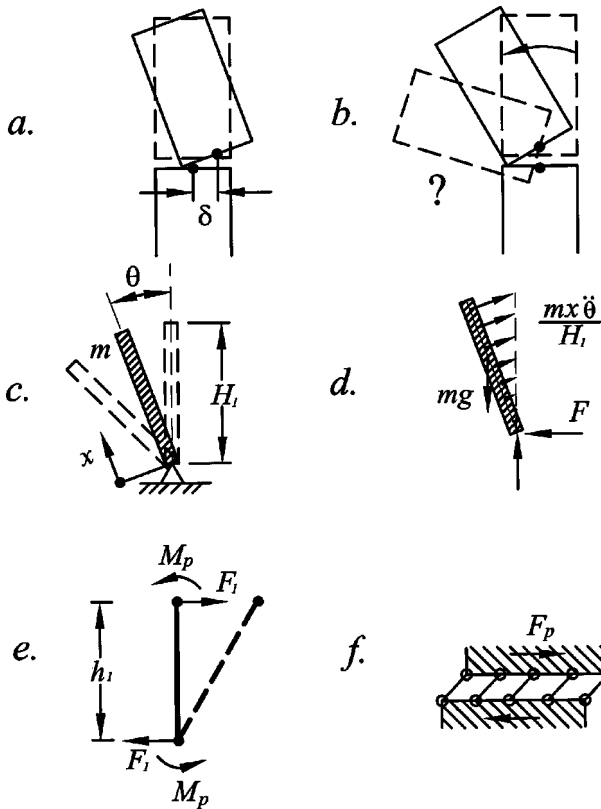

Fig. 3. Pivoting of upper part of tower about its base, (a,b) with and without horizontal shear at base; (c) Model for simplified analysis; (d) Free-body diagram with inertia forces; (d,e) Plastic horizontal shearing of columns in critical floor at base

Appendix II. Why Didn't the Upper Part Pivot About Its Base?

Since the top part of the South Tower tilted [Fig. 3(a)], many people wonder: Why didn't the upper part of the tower fall to the side like a tree, pivoting about the center of the critical floor [Fig. 3(b)]. To demonstrate why, and thus to justify our previous neglect of tilting, is an elementary exercise in dynamics.

Assume the center of the floor at the base of the upper part [Fig. 3(b)] to move for a while neither laterally nor vertically, i.e., act as a fixed pivot. Equating the kinetic energy of the upper part rotating as a rigid body about the pivot at its base [Fig. 3(c)] to the loss of the gravitational potential energy of that part (which is here simpler than using the Lagrange equations of motion), we have $mg(1 - \cos \theta)H_1/2 = (m/2H_1) \int_0^{H_1} (\dot{\theta}x)^2 dx$ where x = vertical coordinate [Fig. 3(c)]. This provides

$$\dot{\theta} = \sqrt{\frac{3g}{H_1}(1 - \cos \theta)}, \quad \ddot{\theta} = \frac{3g}{2H_1} \sin \theta \quad (4)$$

where θ = rotation angle of the upper part; H_1 = its height; and the superposed dots denote time derivatives [Fig. 3(c)].

Considering the dynamic equilibrium of the upper part as a free body, acted upon by distributed inertia forces and a reaction with horizontal component F at base [Fig. 3(d)], one obtains $F = \int_0^{H_1} (m/H_1) \ddot{\theta} \cos \theta x dx = \frac{1}{2} H_1 m \ddot{\theta} \cos \theta = \frac{3}{8} mg \sin 2\theta$. Evidently, the maximum horizontal reaction during pivoting occurs for $\theta = 45^\circ$, and so

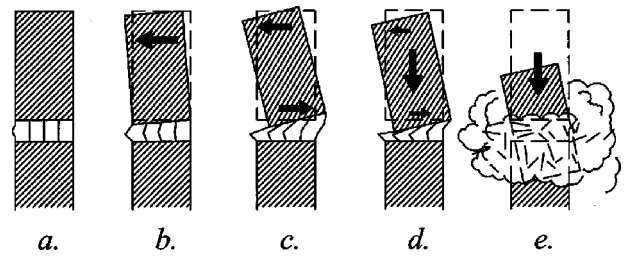

Fig. 4. Scenario of tilting of upper part of building (South Tower)

$$F_{\max} = \frac{3}{8} mg = \frac{3}{8} P_0 \approx 320 \text{ MN} \quad (5)$$

where, for the upper part of South Tower, $m \approx 87 \times 10^6 \text{ kg}$.

Could the combined plastic shear resistance F_p of the columns of one floor [Fig. 3(f)] sustain this horizontal reaction? For plastic shear, there would be yield hinges on top and bottom of each resisting column; Fig. 3(e) (again, aiming only at an optimistic upper bound on resistance, we neglect fracture). The moment equilibrium condition for the column as a free body shows that each column can at most sustain the shear force $F_1 = 2M_p/h_1$ where $h_1 \approx 2.5 \text{ m}$ = effective height of column, and $M_p \approx 0.3 \text{ MN m}$ = estimated yield bending moment of one column, if cold. Assuming that the resisting columns are only those at the sides of the framed tube normal to the axis of rotation, which number about 130, we get $F_p \approx 130F_1 \approx 31 \text{ MN}$. So, the maximum horizontal reaction to pivoting would cause the overload ratio

$$F_{\max}/F_p \approx 10.3 \quad (6)$$

if the resisting columns were cold. Since they are hot, the horizontal reaction to pivoting would exceed the shear capacity of the heated floor still much more (and even more if fracture were considered).

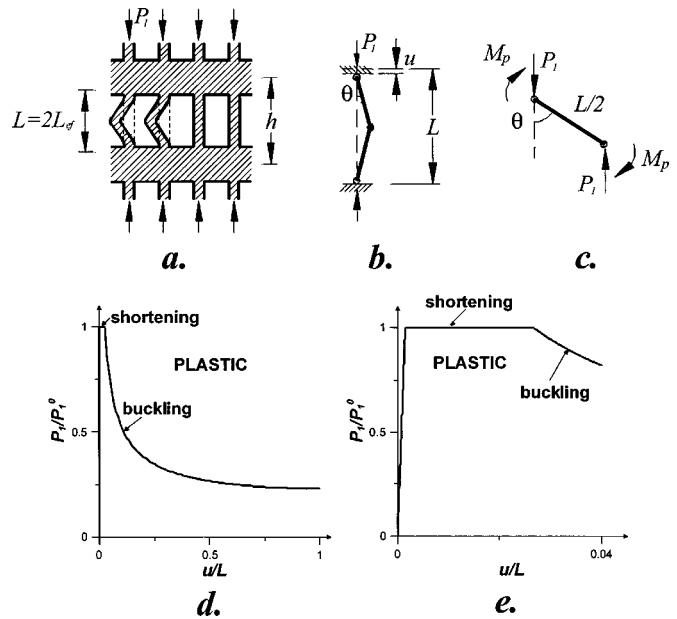

Fig. 5. (a) Plastic buckling of columns; (b) Plastic hinge mechanism; (c) Free-body diagram; (d) Dimensionless diagram of load P_1 versus axial shortening u of columns of the towers if the effects of fracture and heating are ignored; and (e) Beginning of this diagram in an expanded horizontal scale (imperfections neglected)

Since F is proportional to $\sin 2\theta$, its value becomes equal to the plastic limit when $\sin 2\theta=1/10.3$. From this we further conclude that the reaction at the base of the upper part of South Tower must have begun shearing the columns plastically already at the inclination

$$\theta \approx 2.8^\circ \quad (7)$$

The pivoting of the upper part must have started by an asymmetric failure of the columns on one side of building, but already at this very small angle the dynamic horizontal reaction at the base of the upper part must have reduced the vertical load capacity of the remaining columns of the critical floor (even if those were not heated). That must have started the downward motion of the top part of the South Tower, and afterwards its motion must have become predominantly vertical (Fig. 4). Hence, a vertical impact of the upper part onto the lower part must have been the dominant mechanism.

Finally, note that the horizontal reaction F_{\max} is proportional to the weight of the pivoting part. Therefore, if a pivoting about the center of some lower floor were considered, F_{\max} would be still larger.

Appendix III. Plastic Load-Shortening Diagram of Columns

Normal design deals only with initial bifurcation and small deflections, in which the diagram of load versus axial shortening of an elasto-plastic column exhibits hardening rather than softening. However, the columns of the towers suffered very large plastic deflections, for which this diagram exhibits pronounced softening. Fig. 5 shows this diagram as estimated for these towers. The diagram begins with plastic yielding at load $P_1^0 = A_1 f_y$, where A_1 = cross section area of one column and f_y = yield limit of steel. At axial shortening 3%, three plastic hinges form as shown in Fig. 5 (if we assume, optimistically, fixed ends). From the condition of moment equilibrium of the half-column as a free body (Fig. 5),

the axial load then is $P_1 = 4M_p/L \sin \theta$, while, from the buckling geometry, the axial shortening is $u = L(1 - \cos \theta)$, where L = distance between end hinges. Eliminating plastic rotation θ , we find that the plastic load-shortening diagram is given by

$$P_1 = \frac{4M_p}{L\sqrt{1 - [1 - (u/L)]^2}} \quad (8)$$

which defines the curve plotted in Fig. 5. This curve is an optimistic upper bound since, in reality, the plastic hinges develop fracture (Bažant and Planas 1998), and probably do so already at rather small rotations.

Note Added in Proof

An addendum to this paper will be published in the March 2002 issue of the *Journal of Engineering Mechanics*. An edited manuscript containing the information in the addendum was received by ASCE on October 13, 2001.

References

- American Media Specials*. (2001). September, Boca Raton, Fla.
- Bažant, Z. P., and Cedolin, L. (1991). *Stability of structures: Elastic, inelastic, fracture and damage theories*, Oxford University Press, New York.
- Bažant, Z. P., and Kaplan, M. F. (1996). *Concrete at high temperatures*, Longman—Addison-Wesley, London.
- Bažant, Z. P., and Planas, J. (1998). *Fracture and size effect of concrete and other quasibrittle materials*, CRC Press, Boca Raton, Fla.
- Jirásek, M., and Bažant, Z. P. (2002). *Inelastic analysis of structures*, Wiley, New York.
- Levy, M., and Salvadori, M. (1992). *Why buildings fall down*, W. W. Norton, New York.
- “Massive assault doomed towers.” (2001). *Eng. News-Rec.*, 247(12), 10–13.

Discussion of “Why Did the World Trade Center Collapse?—Simple Analysis” by Zdeněk P. Bažant and Yong Zhou

January 2002, Vol. 128, No. 1, pp. 2–6.

DOI: 10.1061/(ASCE)0733-9399(2002)128:1(2)

K. Sivakumar¹

¹Lecturer, Dept. of Civil Engineering, Karunya Institute of Technology-Anna Univ., Coimbatore 641 114, India. E-mail: kovaisiva@indiatimes.com

The writers deserve commendation for their lucid analysis of the World Trade Center collapse. The discussor would like to raise the following points.

1. The writers have mentioned that the fracture of hinges at the column connections must have caused the load capacity to drop drastically. More often in many tall buildings the floor-to-floor heights are not uniform and differ considerably at the bottom floors and at certain few top floor levels. Because of the creep buckling and differential shortening of the columns the connections give away, as they cannot resist any secondary moments. Hence, the hinge connections do not influence the failure of the columns and the converse is not true. As such, there is no scope for the formation of a plastic mechanism.

2. The discussor does not agree with the contention of the writers that the walls of the framed tube are pushed apart during the collapse. The structure being a tubular one, there is a complete void near to the center of gravity of the tower. During collapse the core columns will tend to fall inwardly and the perimeter columns also follow suit. Also, the upper part can partly wedge within the emptied framed tube of the lower part, only when the upper floor can fall as a single block. The core columns, floor trusses, and the perimeter columns separate out at collapse and fall mostly as individual units onto the lower floor and wedging is not possible.

3. The aircraft had hit the North Tower between the 90 and 96 floors and the impact was an almost centered one. But, the South Tower was hit by an aircraft between the 75 and 84 floors and the impact was an off-centered one affecting the corner portion of the building heavily. The 78th floor of the South Tower had a sky lobby and could have had a different structural arrangement, with a load capacity lower than that of the other floors. The off-centered impact could have produced a torque, which might have influenced the tilting of the upper part of the South Tower. It is interesting to note that the destroyed floors of the North Tower by direct impact of the aircraft had no sky lobby floor.

4. The columns in the floor that were directly hit by the aircraft lost their capacity to transmit and bear loads any further. Instead, they hung onto the top floors and because of their enormous self-weight exerted a pulling force on the floors above leading ultimately to a pancake failure of the tower. This is evident in the early failure of the South Tower where the number of floors, above the direct hit destroyed floors, is higher than the North Tower.

5. The bending rigidity index (BRI) (Taranath 1998) of the towers is 33, implying a greater flexibility. After the impact of the aircraft, the South Tower because of its flexibility swayed for a

duration of around 7–10 s. If the upper part of the South Tower has to pivot about its base, it should have happened during the period of sway, by shifting the center of gravity away by several feet, which is impossible.

Reference

Taranath, S. B. (1998). *Steel, concrete, and composite design of tall buildings*, 2nd Ed., McGraw-Hill, New York.

Closure to “Why Did the World Trade Center Collapse?—Simple Analysis” by Zdeněk P. Bažant and Yong Zhou

January 2002, Vol. 128, No. 1, pp. 2–6.

DOI: 10.1061/(ASCE)0733-9399(2002)128:1(2)

Zdeněk P. Bažant, F.ASCE,¹ and Yong Zhou²

¹McCormick School Professor and W.P. Murphy Professor of Civil Engineering and Materials Science, Northwestern Univ., 2145 Sheridan Rd., Evanston, IL 60208. E-mail: z-bazant@northwestern.edu

²Graduate Research Assistant, Northwestern Univ., Evanston, IL 60208.

Srivakumar’s comments are thought provoking and deeply appreciated. However, although his five points introduce interesting connotations, the writers cannot agree with his reservations and objections, for the following reasons.

1. It is not true that “there is no scope for the formation of a plastic failure mechanism.” Even though the connection is probably weaker than the column itself, its moment capacity is not zero, which means that the failing connection will not act as a hinge but as a plastic hinge (or fracturing hinge). Moreover, even if the connections are weaker than the columns, the plastic hinges will not necessarily form at the connections because the connections might not in general lie at the locations that create the failure mechanism with the lowest energy dissipation requirement.

2. It was not stated in the paper that “the walls of the framed tube are pushed apart during collapse.” What was stated in the paper is that one may consider the *possibility* that “the upper part is partly wedged within the emptied framed tube of the lower part, pushing the walls of the framed tube apart” (p. 2). The writers cannot agree with the statement that the “wedging is not possible.” This possibility cannot be excluded. But the point is anyway extraneous. The wedging was not considered in the analysis because the stated aim was to prove that the towers must have collapsed. For that purpose, the most optimistic assumptions about the structure resistance had to be made, and the assumption of wedging would not be of that kind.

3. While it is of course true that the off-center impact of aircraft into the South Tower must have “produced a torque,” this torque could have affected only the initial vibrations of the tower lasting less than a minute and could not have had any effect on

the collapse which occurred much later. The tilting of the upper part observed during the collapse must have been caused by an off-center hole in the building but not by the initially produced torque.

4. It is dubious to say that “the columns in the floor that were directly hit by the aircraft.” ... “hang on top of the floors and because of their enormous self-weight exert a pulling force on the

floors above.” They of course exert some force, but compared to the load from the upper part this force is negligible.

5. The writers agree that the pivoting of the upper part of the South Tower about its base was not possible during the initial period of swaying after the impact. But, what the analysis addressed was the question of pivoting during the collapse, which was shown to have little effect.

